

**John Deere
444D, 544D and 644D
Loader
Repair**

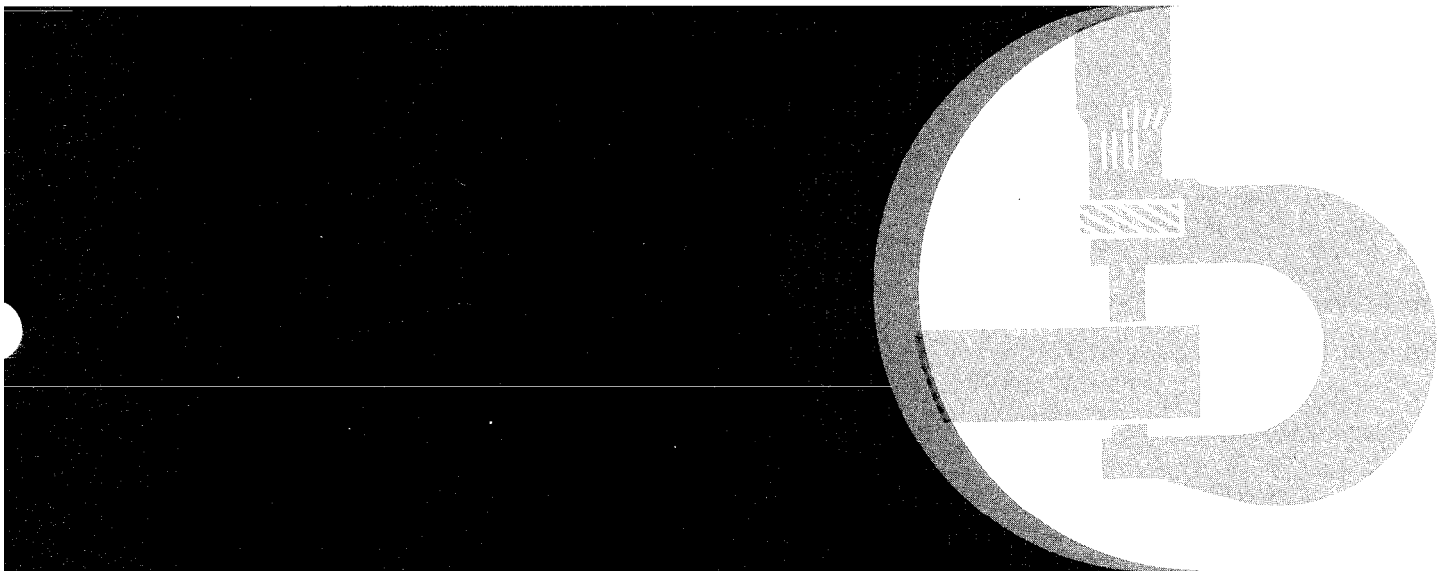

TECHNICAL MANUAL

TM-1341 (Oct-87)



LITHO IN U.S.A.

JOHN DEERE DEALERS

IMPORTANT: Please remove this page and route through your service department.

This is a complete revision for TM-1341, 444D/544D/644D Loader.

Binder and tabs from old manual may be saved and used with this bound manual.

The new pages are dated (Oct-87). Listed below is a brief explanation of "WHAT" was changed and "WHY" it was changed.

This manual was revised:

1. To include thrush washer in transmission case for first turbine drive gear.
2. To clarify assembly instruction for reverse range and low range clutch packs.
3. Slow idle for 644D has been increased to 900 ± 25 rpm.
4. To add direct acting relief valve for use in later units.

T64;1341 DCSR 061187

444D, 544D, AND 644D LOADERS TECHNICAL MANUAL TM-1341 (Oct-87)

SECTION AND GROUP CONTENTS

SECTION I—GENERAL INFORMATION

- Group I—Introduction and Safety Information
- Group II—General Specifications
- Group III—Torque Values
- Group IV—Fuels and Lubrication
- Group V—Inspection Procedures

SECTION 01—WHEELS

- Group 0110—Powered Wheels and Fastenings

SECTION 02—AXLES AND SUSPENSION SYSTEMS

- Group 0200—Removal and Installation
- Group 0210—Differential or Bevel Drive
Differential and Differential Lock
- Group 0225—Input Drive Shafts and U-Joints
- Group 0250—Axle Shafts, Bearings and
Reduction Gears
- Group 0260—Hydraulic System
Unloading Valve and Differential
Lock Valve

SECTION 03—TRANSMISSION (IN- CLUDES TORQUE CONVERTER)

- Group 0300—Removal and Installation
- Group 0315—Controls Linkage
- Group 0325—Input Drive Shafts and U-Joints
- Group 0350—Gears, Shafts, Bearings and
Power Shift Clutch
Transmission and Torque Converter

SECTION 03—TRANSMISSION (IN- CLUDES TORQUE CONVERTER— CONTINUED)

- Group 0360—Hydraulic System
Oil Pump, Control Valve, Oil Cooler,
Oil Cooler Thermal Bypass Valve,
Clutch Cut-Off Solenoid Valve

SECTION 04—ENGINE

- 5.4 L (329 Cu In.)—444D, 544D
- 5.9 L (359 Cu In.)—444D, 544D
- 6.8 L (414 Cu In.)—444D, 544D
- 7.6 L (466 Cu In.)—644D

*NOTE: For repair on 5.9 L (359 cu. in.) engines, see
CTM-4; 7.6 L (466 Cu. In.) engines, see CTM-1.*

- Group 0400—Removal and Installation
Oil Pan
Fuel Injection Pump
Fuel Injection Lines and Nozzles
Turbocharger
Water Pump
Thermostats
Fuel Transfer Pump
Starting Motor

All information, illustrations and specifications contained in this technical manual are based on the latest information available at the time of publication. The right is reserved to make changes at any time without notice.

Copyright© 1987
DEERE & COMPANY
Moline, Illinois
All Rights Reserved
A JOHN DEERE ILLUSTRATION
Previous Editions
Copyright© 1986 Deere & Company
Copyright© 1985 Deere & Company

T64;1341 J6 041187

SECTION AND GROUP CONTENTS—Continued

SECTION 05—ENGINE AUXILIARY SYSTEMS

- Group 0505—Cold Weather Starting Aids
- Group 0510—Cooling Systems
- Group 0515—Speed Controls And Fuel Shut-Off Linkage
- Group 0520—Intake System
- Group 0530—External Exhaust System
- Group 0560—External Fuel Supply Systems

SECTION 06—TORQUE CONVERTER

- See Group 0350 For Torque Converter Repair

SECTION 07—DAMPENER DRIVE

- Group 0752—Elements

SECTION 09—STEERING SYSTEM

- Group 0930—Secondary Steering
- Group 0960—Hydraulic System
 - Steering Valve, Steering Column
 - Priority Valve, Steering Cylinder,
 - Crossover Relief Valve, Cushion Valve

SECTION 10—SERVICE BRAKES

- Group 1011—Active Elements
- Group 1015—Controls Linkage
- Group 1060—Hydraulic System
 - Brake Valve, Brake Accumulator,
 - Brake Pump, Brake System Filter,
 - Unloading Valve and Differential Lock Valve

SECTION 11—PARK BRAKE

- Group 1111—Active Elements
 - Brake Assembly
- Group 1115—Controls Linkage

SECTION 16—ELECTRICAL SYSTEMS

- Group 1671—Batteries, Support and Cables
- Group 1672—Alternator, Regulator and Charging System Wiring
- Group 1673—Lighting System
- Group 1674—Wiring Harness and Switches
- Group 1675—System Controls
 - Transmission Clutch Cut-Off,
 - Differential Lock, Boom
 - Height Kickout and Return-To-Dig Components
- Group 1676—Instruments and Indicators

SECTION 17—FRAME, CHASSIS, OR SUPPORTING STRUCTURE

- Group 1740—Frame Installation
- Group 1746—Frame Bottom Guards
- Group 1749—Chassis Weights
 - Side and Rear Weights

SECTION 18—OPERATOR'S STATION

- Group 1800—Removal and Installation
- Group 1810—Operator Enclosure
- Group 1821—Seat and Seat Belt
- Group 1830—Heating and Air Conditioning

SECTION 19—SHEET METAL AND STYLING

- Group 1921—Grille and Grille Housing

SECTION 20—SAFETY, CONVENIENCE AND MISCELLANEOUS

- Group 2004—Horn and Warning Devices

SECTION 31—LOADER

- Group 3102—Buckets
- Group 3115—Controls Linkage
- Group 3140—Frames
- Group 3160—Hydraulic System
 - Loader Control Valve, Hydraulic Pump, Boom, Bucket, Multi-Purpose Bucket, and Lumber Fork Cylinders,
 - Hydraulic Filter, Reservoir, Suction Screen, Pump Relief Valve

SECTION 99—DEALER FABRICATED TOOLS

T64:1341 J8 021187

SUPPORT RAISED EQUIPMENT

Raised equipment must be supported before working under it.

If a support is not available, lower equipment to the ground.

T82;FLSA O 010485

AVOID POWER LINES

Keep away from power lines. Serious injury or death may result. Never move any part of the machine or load closer to power line than 10 ft (3 m) plus twice the line insulator length.

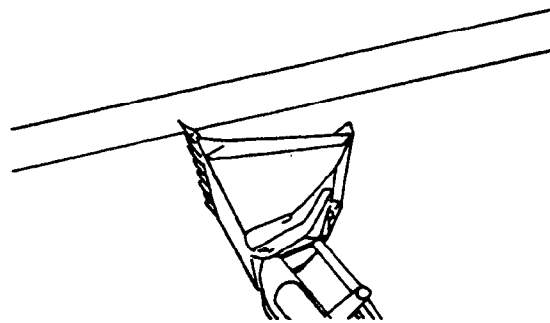

018;T6133AK T82;FLSA Q 100685

OBSERVE SERVICE PRECAUTIONS

Keep ALL equipment free of dirt and oil.

Clean oil, grease, mud, ice or snow from the operator's station, steps and hand rails.

DO NOT remove the radiator cap unless the engine is cool. Then loosen the cap slowly to the stop. Release all pressure before you remove the cap.

Check the exhaust system regularly for leaks.

Release hydraulic pressure before you work on the hydraulic system.

Disconnect negative (—) battery cable.

When you check hydraulic pressure, be sure to use the correct test gauge.

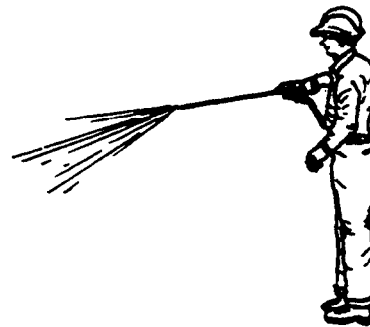

018;T5813AM T82;FLPD P 130886

Group II
GENERAL SPECIFICATIONS

444D LOADER

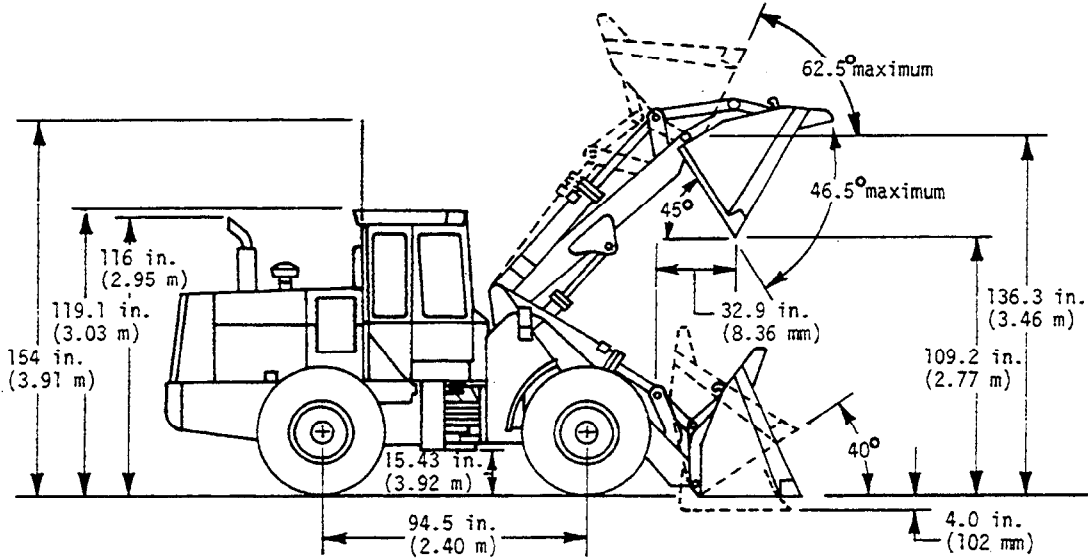

Engine:

John Deere 6-cylinder turbocharger diesel	90 SAE hp (67 kw)
Bore and stroke	
Pin (—511476)	4.02 x 4.33 in. (102 x 110 mm)
Pin (511477—)	4.19 x 4.33 in. (106 x 110 mm)
Piston displacement	
Pin (—511476)	3.29 cu. in. (5.392 L)
Pin (511477—)	3.59 cu. in. (5.833 L)
Lubrication	Pressure system with full-flow filter
Cooling	Pressurized with thermostat and controlled bypass
Fan	Blower
Dual-stage air cleaner with restriction indicator	Dry
Electrical system	12-volt with alternator
Batteries (one 12-volt)	
Cold cranking capacity at 0°F (−18°C)	625 amps
Reserve capacity	170 min. ea.
Alternator: standard	42 amps
optional with cab	90 amps

Differentials:

Front and rear	Standard
Front hydraulic differential lock with capture circuit	Optional
Front No Spin	Optional

Drive Axles:

- Inboard-mounted planetary gears to each wheel.
- Front axle fixed.
- Rear axle oscillates 22° total (15.6 in (396 mm) vertical travel at center of tire).

018;T6140AC 05T;115 C72 140886

General Specifications

Torque Converter Twin-turbine

Transmission Power shift planetary

Forward Speeds

	mph	km/h
1	0—2.9	0—4.7
2	2.9—6.5	4.7—10.5
3	0—11.0	0—17.7
4	11.0—24.6	17.7—39.6

Reverse Speeds

1	0—3.9	0—6.3
2	3.9—8.8	6.3—14.2

NOTE: Shift from 1st to 2nd and 3rd to 4th is automatic.

Brakes:

Service:

- Power-actuated, 4-wheel, inboard-mounted, wet-disk.
- Foot-operated by either pedal.
- Left pedal also disconnects transmission.
- External inspection.
- Low brake pressure warning light and buzzer.

Park:

- Expanding shoe on transmission output shaft, foot-operated.
- Transmission disconnects with park brake applied.
- Warning light on instrument panel.

Steering:

- Turning radius 13 ft 10 in. (4.22 m) measure to center line of outside tire
- Secondary steering—if equipped: Meets the requirements of SAE J53.

Main Hydraulic and Steering System @ fast idle:

Hydraulic System Relief	2250—2450 psi (15 514—15 895 kPa) (155—159 bar)
Boom Raise Circuit Relief	2500—2625 psi (17 238—18 005 kPa) (173—180 bar)
Bucket Rollback Circuit Relief	2500—2625 psi (17 238—18 005 kPa) (173—180 bar)
Bucket Dump Circuit Relief	850—1050 psi (5 861—7 240 kPa) (59—72 bar)
Clam Open Circuit Relief	2500—2625 psi (17 238—18 005 kPa) (173—180 bar)
Clam Close Circuit Relief	2500—2625 psi (17 238—18 005 kPa) (173—180 bar)
Maximum Steering System Pressure	2400—2500 psi (16 550—17 240 kPa) (165—172 bar)
Steering Crossover Relief Valve Pressure	3000—3200 psi (20 685—22 060 kPa) (207—220 bar)

Brake and Differential Lock Hydraulic System:

Unloading Valve Pressure Setting (Closing)	1800 psi (12 411 kPa) (124 bar)
(Opening)	2300 psi (15 859 kPa) (159 bar)
Differential Lock Circuit Pressure	600 psi (4 137 kPa) (41 bar)
Transmission System Pressure	125—170 psi (862—1 172 kPa) (8.6—11.7 bar)

Maximum lift capacity with standard equipment

Maximum height	7,310 lb (3320 kg)
Ground level	18,790 lb (8525 kg)

05T;115 C73 140886

General Specifications

Tires:

13.0—24, 8 PR, G2
 15.5—25, 8 PR, L2
 15.5—25, 12 PR, L2
 15.5—25, 1 STAR, XRAT

17.5—25, 12 PR, L2
 *18.4—26, 10 PR, LS2
 *23.1—26, 10 PR, LS2

Cold Tire Inflation Pressure

50 psi (345 kPa) (3.5 bar)
 45 psi (310 kPa) (3.1 bar)
 55 psi (380 kPa) (3.8 bar)
 front 50 psi (340 kPa) (3.4 bar)
 rear 30 psi (210 kPa) (2.1 bar)
 50 psi (340 kPa) (3.4 bar)
 30 psi (210 kPa) (2.1 bar)
 25 psi (170 kPa) (1.7 bar)

**Use with log loader*

Wheel Treads:

Front and rear 70.0 in. (1.78 m)

Refill Capacities:

	U.S.	Metric
Cooling System	24 qt.	23 L
Fuel tank	50 gal.	189 L
Engine crankcase and filter	12 qt.	11.4 L
Transmission case and filter	8.5 gal	32.2 L
Front and rear differential	17 qt.	16 L
Hydraulic reservoir	64 qt.	61 L
Weight:	19, 223 lb	8727 kg

NOTE: *Specifications and design subject to change without notice. Wherever applicable, specifications are in accordance with ICED and SAE standards. Except where otherwise noted, specifications are based on a machine equipped with all standard equipment, 15.5—25, 8 PR loader-tread tires with 940 lb (426 kg) CaC₁₂ solution in rear tires, ROPS cab, full fuel tank, and 175 lb (79 kg) operator.*

T82;FLSP H 140685

544D LOADER

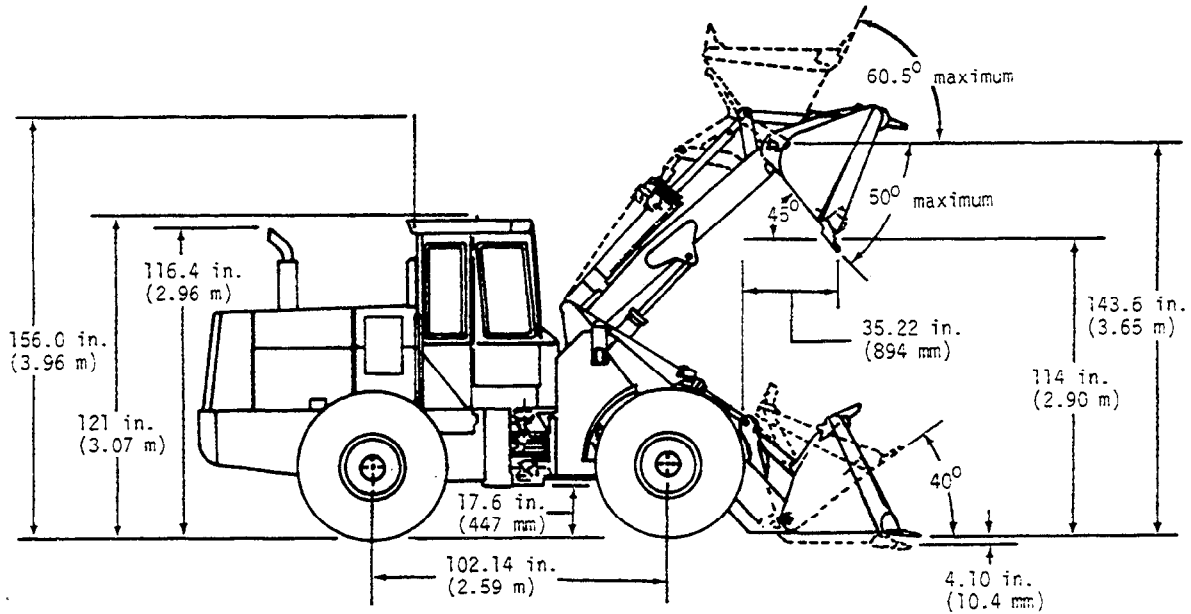

Engine:

John Deere 6-cylinder turbocharger diesel	115 SAE hp (86 kw)
Bore and stroke	4.19 x 5 in. (106.5 x 127 mm)
Piston displacement	414 cu. in. (6.785 L)
Lubrication	Pressure system with full-flow filter
Cooling	Pressurized with thermostat and controlled bypass
Fan	Blower
Aspirated dual-stage air cleaner with restriction indicator	Dry
Electrical system	12-volt with alternator
Batteries (one 12-volt)	
Cold cranking capacity at 0°F (-18°C)	625 amps
Reserve capacity	170 min. ea.
Alternator: standard	42 amps
optional with cab	90 amps

Torque Converter

Twin-turbine

Transmission

Power shift planetary

Forward Speeds

	mph	km/h
1	0—3.1	0—5.0
2	3.1—7.3	5.0—11.7
3	0—11.7	0—18.8
4	11.7—27.9	18.8—45.0

Reverse Speeds

1	0—4.2	0—6.8
2	4.2—9.9	6.8—16.0

NOTE: Shift from 1st to 2nd and 3rd to 4th is automatic.

25A/T6140AD T82/FLPD S 310785

General Specifications

Differentials:

Front and rear	Standard
Front hydraulic differential lock with capture circuit	Optional
Front No Spin	Optional

Drive Axles:

- Inboard-mounted planetary gears to each wheel.
- Front axle fixed.
- Rear axle oscillates 22° total (13.5 in (343 mm) vertical travel at center of tire).

Brakes:

Service:

- Power-actuated, 4-wheel, inboard-mounted, wet-disk.
- Foot-operated by either pedal.
- Left pedal also disconnects transmission.
- External inspection.
- Low brake pressure warning light and buzzer.

Park:

- Expanding shoe on transmission output shaft, foot-operated.
- Transmission disconnects with park brake applied.
- Warning light on instrument panel.

Steering:

- Turning radius 14 ft 7 in. (4.44 m) measured to center line of outside tire
- Secondary steering—if equipped: Meets the requirements of SAE J53.

Main Hydraulic and Steering System:

Hydraulic System Relief	2625—1750 psi (18 099—18 960 kPa) (179—189 bar)
Boom Raise Circuit Relief	2875—3000 psi (19 823—20 680 kPa) (198—207 bar)
Bucket Rollback Circuit Relief	2875—3000 psi (19 823—20 680 kPa) (198—207 bar)
Bucket Dump Circuit Relief	1750—1950 psi (12 066—13 445 kPa) (119—134 bar)
Clam Open Circuit Relief	2875—3000 psi (19 823—20 680 kPa) (198—207 bar)
Clam Close Circuit Relief	2875—3000 psi (19 823—20 680 kPa) (198—207 bar)
Maximum Steering System Pressure	2400—2500 psi (16 550—17 240 kPa) (166—172 bar)
Steering Crossover Relief Valve Pressure	3000—3200 psi (20 685—22 060 kPa) (207—220 bar)

Brake and Differential Lock Hydraulic System:

Unloading Valve Pressure Setting (Closing)	1800 psi (12 411 kPa) (124 bar)
(Opening)	2300 psi (15 859 kPa) (159 bar)
Differential Lock Circuit Pressure	600 psi (4 137 kPa) (41 bar)
Transmission System Pressure	125—170 psi (862—1 172 kPa) (18.6—11.7 bar)

Maximum lift capacity with standard equipment

Maximum height	10,239 lb (4 654 kg)
Ground level	25,009 lb (11 368 kg)

T82;FLSP E 081185

General Specifications

Tires:

- 14.0—24, 10 PR, G2
- 14.0—24, 12 PR, G2
- 17.5—25, 12 PR, L2
- 17.5—25, 12 PR, L3
- 17.5—25, 1 START, XRAT

- 20.5—25, 12 PR, L3
- 20.5—25, 12 PR, L3
- *23.1—26, 10 PR, LS2
- *28.1—26, 14 PR, LS2

Cold Tire Inflation Pressure

- 55 psi (380 kPa) (3.8 bar)
- 65 psi (410 kPa) (4.1 bar)
- 50 psi (345 kPa) (3.5 bar)
- 50 psi (345 kPa) (3.5 bar)
- front 50 psi (345 kPa) (3.5 bar)
- rear 30 psi (210 kPa) (2.1 bar)
- 50 psi (345 kPa) (3.5 bar)
- 50 psi (345 kPa) (3.5 bar)
- 25 psi (170 kPa) (1.7 bar)
- 30 psi (210 kPa) (2.1 bar)

**Use with feller buncher and log loader*

Wheel Treads:

- Front and rear 70.0 in. (1.78 m)
- Front and rear w/20, 5—25 tires 80.0 in. (2.03 m)

Refill Capacities:

	U.S.	Metric
Cooling System	24 qt.	23 L
Fuel tank	50 gal.	189 L
Engine crankcase and filter	20 qt.	19 L
Transmission case and filter	8.5 gal	32 L
Front differential	24 qt.	23 L
Rear differential	24 qt.	23 L
Hydraulic reservoir	64 qt.	61 L
Weight:	22, 665 lb	10 290 kg

NOTE: Specifications and design subject to change without notice. Wherever applicable, specifications are in accordance with ICED and SAE standards. Except where otherwise noted, specifications are based on a machine equipped with all standard equipment, 17.5—25, 12 PR, L2 tires with 1180 lb (535 kg) CaC1₂ solution in rear tires, ROPS cab, full fuel tank, and 175 lb (79 kg) operator.