

# **325, 335 and 345 Lawn and Garden Tractors**

Serial No. (70001 - )

## **TECHNICAL MANUAL**

**John Deere  
Worldwide Commercial and  
Consumer Equipment Division**

**TM1760 (28May99)**



M82901

This technical manual is written for an experienced technician and contains sections that are specifically for this product. It is a part of a total product support program.

The manual is organized so that all the information on a particular system is kept together. The order of grouping is as follows:

- Table of Contents
- General Diagnostic Information
- Specifications
- Electrical Wiring Harness Legend
- Component Location
- System Schematic
- Wiring Harness
- Troubleshooting Chart
- Theory of Operation
- Diagnostics
- Tests & Adjustments
- Repair













*Note: Depending on the particular section or system being covered, not all of the above groups may be used.*

Each section will be identified with a symbol rather than a number. The groups and pages within a section will be consecutively numbered.

We appreciate your input on this manual. To help, there are postage paid post cards included at the back. If you find any errors or want to comment on the layout of the manual please fill out one of the cards and mail it back to us.

All information, illustrations and specifications in this manual are based on the latest information available at the time of publication. The right is reserved to make changes at any time without notice.

COPYRIGHT© 1999  
 Deere and Co.  
 John Deere Worldwide Commercial and  
 Consumer Equipment Division  
 Horicon, WI  
 All rights reserved

<b>Safety</b>	
<b>Specifications and General Information</b>	
<b>Engine—325 (FH531V)</b>	
<b>Engine—335 (FH601V)</b>	
<b>Engine—345 (FD611V)</b>	
<b>Electrical</b>	
<b>Power Train (Hydrostatic)</b>	
<b>Steering—325</b>	
<b>Steering—335/345</b>	
<b>Brakes</b>	
<b>Hydraulics</b>	
<b>Attachments</b>	
<b>Miscellaneous</b>	<b>M</b>



## RECOGNIZE SAFETY INFORMATION



This is the safety-alert symbol. When you see this symbol on your machine or in this manual, be alert to the potential for personal injury.

Follow recommended precautions and safe servicing practices.

### Understand Signal Words

A signal word—DANGER, WARNING, or CAUTION—is used with the safety-alert symbol. DANGER identifies the most serious hazards.

DANGER or WARNING safety signs are located near specific hazards. General precautions are listed on CAUTION safety signs. CAUTION also calls attention to safety messages in this manual.

## REPLACE SAFETY SIGNS

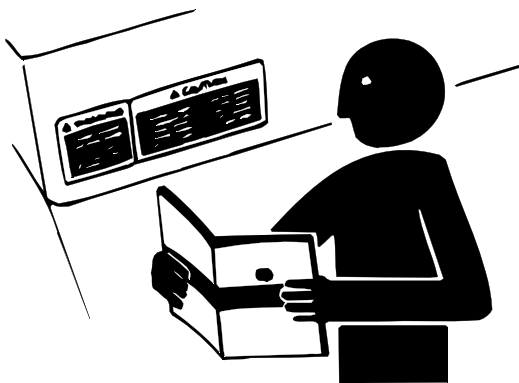

Replace missing or damaged safety signs. See the machine operator's manual for correct safety sign placement.

## HANDLE FLUIDS SAFELY-AVOID FIRES

### Be Prepared For Emergencies

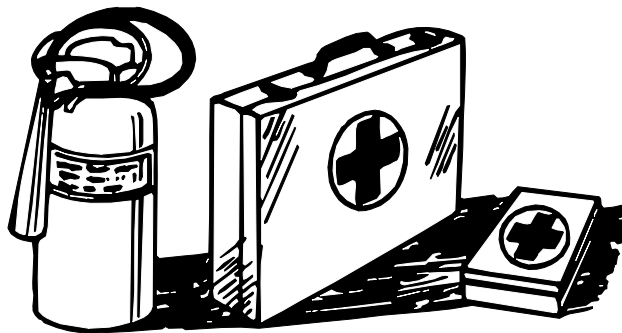

When you work around fuel, do not smoke or work near heaters or other fire hazards.

Store flammable fluids away from fire hazards. Do not incinerate or puncture pressurized containers.

Make sure machine is clean of trash, grease, and debris.

Do not store oily rags; they can ignite and burn spontaneously.

Be prepared if a fire starts.

Keep a first aid kit and fire extinguisher handy.

Keep emergency numbers for doctors, ambulance service, hospital, and fire department near your telephone.

## USE CARE IN HANDLING AND SERVICING BATTERIES

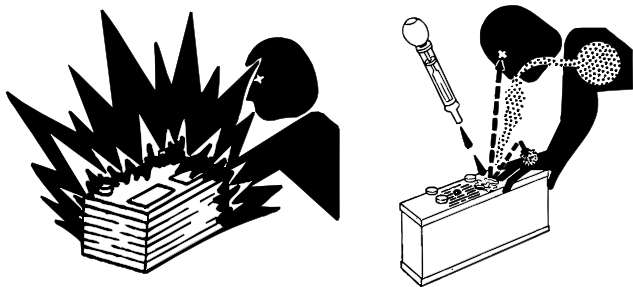

### Prevent Battery Explosions

- Keep sparks, lighted matches, and open flame away from the top of battery. Battery gas can explode.
- Never check battery charge by placing a metal object across the posts. Use a volt-meter or hydrometer.
- Do not charge a frozen battery; it may explode. Warm battery to 16°C (60°F).

### Prevent Acid Burns

- Sulfuric acid in battery electrolyte is poisonous. It is strong enough to burn skin, eat holes in clothing, and cause blindness if splashed into eyes.
- **Avoid acid burns by:**
  1. Filling batteries in a well-ventilated area.
  2. Wearing eye protection and rubber gloves.
  3. Avoiding breathing fumes when electrolyte is added.
  4. Avoiding spilling or dripping electrolyte.
  5. Use proper jump start procedure.
- **If you spill acid on yourself:**
  1. Flush your skin with water.
  2. Apply baking soda or lime to help neutralize the acid.
  3. Flush your eyes with water for 10\_15 minutes.
  4. Get medical attention immediately.
- **If acid is swallowed:**
  1. Drink large amounts of water or milk.
  2. Then drink milk of magnesia, beaten eggs, or vegetable oil.
  3. Get medical attention immediately.

## USE CARE AROUND HIGH-PRESSURE FLUID LINES

### Avoid High-pressure Fluids



Escaping fluid under pressure can penetrate the skin causing serious injury.

Avoid injury from escaping fluid under pressure by stopping the engine and relieving pressure in the system before disconnecting or connecting hydraulic or other lines. Tighten all connections before applying pressure.

Search for leaks with a piece of cardboard. Protect hands and body from high pressure fluids.

If an accident occurs, see a doctor immediately. Any fluid injected into the skin must be surgically removed within a few hours or gangrene may result. Doctors unfamiliar with this type of injury should reference a knowledgeable medical source. Such information is available from Deere & Company Medical Department in Moline, Illinois, U.S.A.

### Avoid Heating Near Pressurized Fluid Lines



Flammable spray can be generated by heating near pressurized fluid lines, resulting in severe burns to yourself and bystanders. Do not heat by welding, soldering, or using a torch near pressurized fluid lines or other flammable materials. Pressurized lines can be accidentally cut when heat goes beyond the immediate flame area.



## **USE SAFE SERVICE PROCEDURES**

### **Wear Protective Clothing**

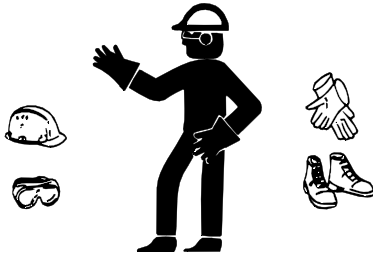

Wear close fitting clothing and safety equipment appropriate to the job.

Prolonged exposure to loud noise can cause impairment or loss of hearing. Wear a suitable hearing protective device such as earmuffs or earplugs to protect against objectionable or uncomfortable loud noises.

Operating equipment safely requires the full attention of the operator. Do not wear radio or music headphones while operating machine.

### **Service Machines Safely**

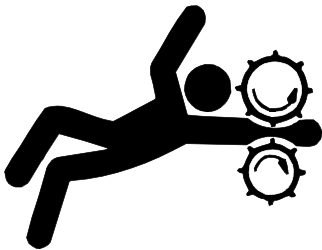

Tie long hair behind your head. Do not wear a necktie, scarf, loose clothing, or necklace when you work near machine tools or moving parts. If these items were to get caught, severe injury could result.

Remove rings and other jewelry to prevent electrical shorts and entanglement in moving parts.

### **Use Proper Tools**

Use tools appropriate to the work. Makeshift tools and procedures can create safety hazards. Use power tools only to loosen threaded parts and fasteners. For loosening and tightening hardware, use the correct size tools. **DO NOT** use U.S. measurement tools on metric fasteners. Avoid bodily injury caused by slipping wrenches. Use only service parts meeting John Deere specifications.

### **Park Machine Safely**

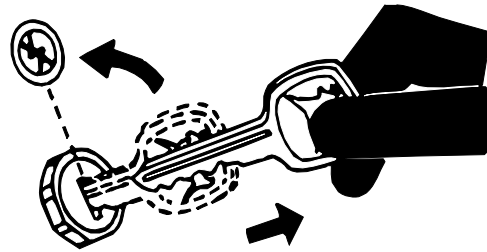

#### **Before working on the machine:**

1. Lower all equipment to the ground.
2. Stop the engine and remove the key.
3. Disconnect the battery ground strap.
4. Hang a "DO NOT OPERATE" tag in operator station.

### **Support Machine Properly And Use Proper Lifting Equipment**

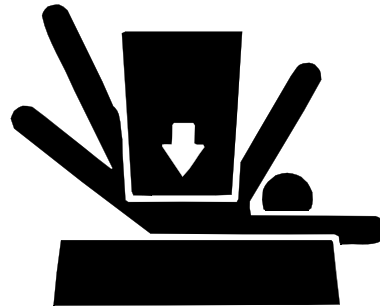

If you must work on a lifted machine or attachment, securely support the machine or attachment.

Do not support the machine on cinder blocks, hollow tiles, or props that may crumble under continuous load. Do not work under a machine that is supported solely by a jack. Follow recommended procedures in this manual.

Lifting heavy components incorrectly can cause severe injury or machine damage. Follow recommended procedure for removal and installation of components in the manual.

### **Work In Clean Area**

#### **Before starting a job:**

1. Clean work area and machine.
2. Make sure you have all necessary tools to do your job.
3. Have the right parts on hand.
4. Read all instructions thoroughly; do not attempt shortcuts.

## Using High Pressure Washers

Directing pressurized water at electronic/electrical components or connectors, bearings, hydraulic seals, fuel injection pumps or other sensitive parts and components may cause product malfunctions. Reduce pressure and spray at a 45 to 90 degree angle.

## Illuminate Work Area Safely

Illuminate your work area adequately but safely. Use a portable safety light for working inside or under the machine. Make sure the bulb is enclosed by a wire cage. The hot filament of an accidentally broken bulb can ignite spilled fuel or oil.

## Work In Ventilated Area

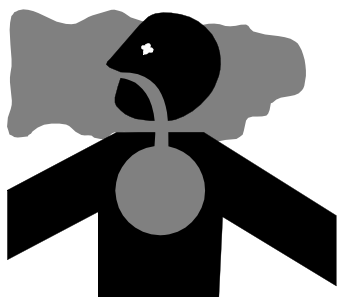

Engine exhaust fumes can cause sickness or death. If it is necessary to run an engine in an enclosed area, remove the exhaust fumes from the area with an exhaust pipe extension.

If you do not have an exhaust pipe extension, open the doors and get outside air into the area.

## WARNING: California Proposition 65

Warning:

Diesel engine exhaust and some of its constituents are known to the State of California to cause cancer, birth defects, and other reproductive harm.

Gasoline engine exhaust from this product contains chemicals known to the State of California to cause cancer, birth defects, or other reproductive harm.

## Remove Paint Before Welding Or Heating

Avoid potentially toxic fumes and dust. Hazardous fumes can be generated when paint is heated by welding, soldering, or using a torch. Do all work outside or in a well ventilated area. Dispose of paint and solvent properly. Remove paint before welding or heating: If you sand or grind paint, avoid breathing the dust. Wear an approved respirator. If you use solvent or paint stripper, remove stripper with soap and water before welding. Remove solvent or paint stripper containers and other flammable material from area. Allow fumes to disperse at least 15 minutes before welding or heating.

## Avoid Harmful Asbestos Dust

Avoid breathing dust that may be generated when handling components containing asbestos fibers. Inhaled asbestos fibers may cause lung cancer.

Components in products that may contain asbestos fibers are brake pads, brake band and lining assemblies, clutch plates, and some gaskets. The asbestos used in these components is usually found in a resin or sealed in some way. Normal handling is not hazardous as long as airborne dust containing asbestos is not generated.

Avoid creating dust. Never use compressed air for cleaning. Avoid brushing or grinding material containing asbestos. When servicing, wear an approved respirator. A special vacuum cleaner is recommended to clean asbestos. If not available, apply a mist of oil or water on the material containing asbestos. Keep bystanders away from the area.



## SERVICE TIRES SAFELY



Explosive separation of a tire and rim parts can cause serious injury or death.

Do not attempt to mount a tire unless you have the proper equipment and experience to perform the job. Always maintain the correct tire pressure. Do not inflate the tires above the recommended pressure. Never weld or heat a wheel and tire assembly. The heat can cause an increase in air pressure resulting in a tire explosion. Welding can structurally weaken or deform the wheel.

When inflating tires, use a clip-on chuck and extension hose long enough to allow you to stand to one side and NOT in front of or over the tire assembly. Use a safety cage if available.

Check wheels for low pressure, cuts, bubbles, damaged rims or missing lug bolts and nuts.



## **AVOID INJURY FROM ROTATING BLADES, AUGERS AND PTO SHAFTS**

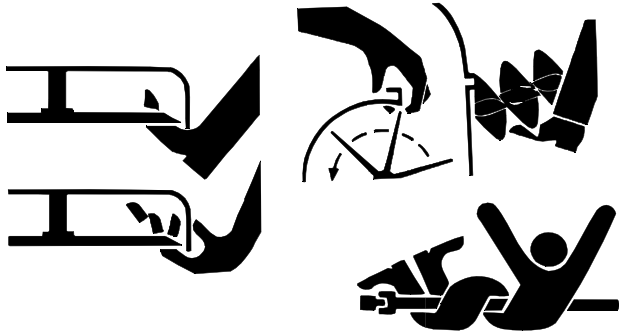

Keep hands and feet away while machine is running. Shut off power to service, lubricate or remove mower blades, augers or PTO shafts.

## **SERVICE COOLING SYSTEM SAFELY**



Explosive release of fluids from pressurized cooling system can cause serious burns.

Shut off machine. Only remove filler cap when cool enough to touch with bare hands. Slowly loosen cap to first stop to relieve pressure before removing completely.

## **HANDLE CHEMICAL PRODUCTS SAFELY**

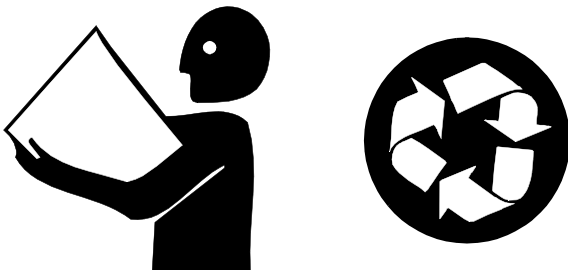

Direct exposure to hazardous chemicals can cause serious injury. Potentially hazardous chemicals used with John Deere equipment include such items as lubricants, coolants, paints, and adhesives.

A Material Safety Data Sheet (MSDS) provides specific details on chemical products: physical and health hazards, safety procedures, and emergency response techniques. Check the MSDS before you start any job using a hazardous chemical. That way you will know exactly what the risks are and how to do the job safely. Then follow procedures and recommended equipment.

## **Dispose of Waste Properly**

Improperly disposing of waste can threaten the environment and ecology. Potentially harmful waste used with John Deere equipment include such items as oil, fuel, coolant, brake fluid, filters, and batteries. Use leakproof containers when draining fluids. Do not use food or beverage containers that may mislead someone into drinking from them. Do not pour waste onto the ground, down a drain, or into any water source. Inquire on the proper way to recycle or dispose of waste from your local environmental or recycling center, or from your John Deere dealer.

## **LIVE WITH SAFETY**



Before returning machine to customer, make sure machine is functioning properly, especially the safety systems. Install all guards and shields.



# CONTENTS



	Page
<b>VEHICLE SPECIFICATIONS</b> .....	<b>3</b>
ENGINE- 325.....	3
ENGINE- 335.....	3
ENGINE- 345.....	4
FUEL SYSTEM .....	4
ELECTRICAL .....	4
PTO DRIVE .....	5
POWER TRAIN .....	5
STEERING .....	5
BRAKES .....	5
HYDRAULICS .....	5
IMPLEMENT LIFT .....	6
MOWER ATTACHMENTS .....	6
WEIGHTS AND DIMENSIONS .....	6
WHEELS AND TIRES .....	6
METRIC FASTENER TORQUE VALUES .....	7
INCH FASTENER TORQUE VALUES .....	8
O-RING SEAL SERVICE RECOMMENDATIONS.....	9
FACE SEAL FITTINGS WITH INCH STUD ENDS TORQUE .....	9
FACE SEAL FITTINGS WITH METRIC STUD ENDS TORQUE.....	10
O-RING FACE SEAL FITTINGS .....	11
O-RING BOSS FITTINGS .....	11
<b>GASOLINE SPECIFICATIONS</b> .....	<b>12</b>
4-CYCLE ENGINES – NORTH AMERICA .....	12
GASOLINE STORAGE .....	12
4-CYCLE ENGINES – EUROPE .....	13
GASOLINE STORAGE .....	13
<b>LUBRICANTS</b> .....	<b>14</b>
4-CYCLE GASOLINE ENGINE OIL –NORTH AMERICA.....	14
4-CYCLE GASOLINE ENGINE OIL –EUROPE .....	14
BREAK-IN ENGINE OIL .....	15
OIL FILTERS .....	15
HYDROSTATIC TRANSMISSION AND HYDRAULIC OIL .....	16
ANTI-CORROSION GREASE SPECIFICATIONS.....	16
ALTERNATIVE LUBRICANTS.....	17
SYNTHETIC LUBRICANTS.....	17
LUBRICANT STORAGE .....	17
MIXING OF LUBRICANTS .....	17
CHASSIS GREASE.....	17
<b>COOLANT SPECIFICATIONS</b> .....	<b>18</b>
GASOLINE ENGINE COOLANT.....	18
GASOLINE ENGINE COOLANT DRAIN INTERVAL.....	18
<b>SERIAL NUMBER LOCATION</b> .....	<b>19</b>
MACHINE IDENTIFICATION NUMBER .....	19



	<b>Page</b>
ENGINE SERIAL NUMBER .....	19
CARBURETOR SERIAL NUMBER .....	19
HYDROSTATIC TRANSMISSION SERIAL NUMBER .....	20

## VEHICLE SPECIFICATIONS

### ENGINE- 325

Make .....	John Deere "K" Series, Air Cooled
Type .....	Gasoline
Model .....	FH531V
Aspiration .....	Natural
Horsepower (SAEJ1940).....	13.4 kW (18 hp)
Cylinders .....	2
Displacement .....	494 cm <sup>3</sup> (30 cu in.)
Stroke/Cycle .....	4 Cycle
Bore .....	68 mm (2.68 in.)
Stroke .....	68 mm (2.68 in.)
Compression Ratio .....	8.3:1
Slow Idle .....	1550 ± 75 rpm
Fast Idle.....	3400 ± 50 rpm
Valves .....	Overhead
Lubrication.....	Pressurized
Oil Filter.....	Full Flow Filter
Cooling System .....	Air Cooled
Air Cleaner .....	Dual Stage Paper Air Filter and Foam Precleaner
Muffler .....	Horizontal discharge below frame
Engine Oil Capacity	
With Filter .....	1.7 L (1.8 U.S. qt)
Without Filter .....	1.6 L (1.6 U.S. qt)

### ENGINE- 335

Make .....	John Deere "K" Series, Air Cooled
Type .....	Gasoline
Model .....	FH601V
Aspiration .....	Natural
Horsepower (SAEJ1940).....	14.9 kW (20 hp)
Cylinders .....	2
Displacement .....	675 cm <sup>3</sup> (41.2 cu in.)
Stroke/Cycle .....	4 Cycle
Bore .....	75.2 mm (2.96 in.)
Stroke .....	76 mm (2.99 in.)
Compression Ratio .....	8.1:1
Slow Idle (Governed).....	1550 ± 75 rpm
Fast Idle.....	3400 ± 50 rpm
Valves .....	Overhead
Lubrication.....	Pressurized
Oil Filter.....	Full Flow Filter
Cooling System .....	Air Cooled
Air Cleaner .....	Dual Stage Paper Air Filter and Foam Precleaner
Muffler .....	Horizontal discharge below frame
Engine Oil Capacity	
With Filter .....	1.7 L (1.8 U.S. qt)
Without Filter .....	1.6 L (1.6 U.S. qt)



**ENGINE- 345**

Make .....	John Deere "K" Series, Liquid Cooled
Type .....	Gasoline
Model .....	FD611V
Aspiration .....	Natural
Horsepower (SAEJ1940) .....	14.9 kW (20 hp)
Cylinders .....	2, V-twin
Displacement .....	585 cm <sup>3</sup> (35.7 cu in.)
Stroke/Cycle .....	4 Cycle
Bore .....	74 mm (2.900 in.)
Stroke .....	68 mm (2.700 in.)
Compression Ratio .....	8.7:1
Slow Idle .....	1550 ± 75 rpm
Fast Idle .....	3400 ± 50 rpm
Valves .....	Overhead
Lubrication .....	Pressurized
Oil Filter .....	Full Flow Filter
Cooling System .....	Liquid Cooled
Coolant Capacity .....	3.1 L (3.3 qt)
Air Cleaner .....	Dual Stage Paper Air Filter and Foam Precleaner
Muffler .....	Horizontal discharge below frame
Engine Oil Capacity	
With Filter .....	1.9 L (2.0 U.S. qt)
Without Filter .....	1.7 L (1.8 U.S. qt)

**FUEL SYSTEM**

Fuel Tank Location .....	Rear
Fuel Tank Capacity (Total) .....	13.2 L (3.50 U.S. gal)
Fuel (min. octane) .....	Unleaded gasoline, 87 octane
Fuel Pump Location	
325 .....	On Right-Hand Side of Engine
335 .....	On Right-Hand Side of Engine
345 .....	On Front of Engine
Fuel Pump Type .....	Diaphragm Vacuum Pulse
Fuel Delivery .....	Float-Type Side Draft Carburetor
Fuel Shut-Off .....	In Fuel Line
Fuel Filter .....	Replaceable, In-line
Fuel Gauge .....	Translucent Fuel Tank

**ELECTRICAL**

Ignition .....	Electronic
Type of Starter .....	Solenoid Shift
Charging System .....	Flywheel Alternator
Charging Capacity:	
325/335 .....	13 amp Regulated
345 .....	17 amp Regulated
Battery Type .....	BCI Group 51
Battery Voltage .....	12 VDC
Electrolyte Capacity .....	1.9 L (2.0 qt)
Battery Cold Cranking amps at -17.8° C (0° F) .....	.500 amps
Battery Reserve Capacity at 26.7° C (80° F) .....	90 minutes

Headlights . . . . . Incandescent, Standard  
 . . . . . (Halogen Bulbs, Optional)  
 Indicator Lights . . . . . Engine Oil Pressure, Battery Charge  
 Coolant Temperature . . . . . 345 only  
 Gauges . . . . . Hourmeter  
 Ignition Interlock Switches . . . . . Neutral Start, Operator Presence, Brake Pedal



**PTO DRIVE**

Type . . . . . V-Belt  
 Clutch Type . . . . . Engine Mounted, Electric

**POWER TRAIN**

Drive Wheels . . . . . Rear  
 Traction Drive . . . . . Hydrostatic, Twin Touch™ Foot Control  
 Transmission . . . . . Hydrostatic, Piston Type  
 Transmission Model . . . . . Kanzaki K70A  
 Transmission Oil Capacity . . . . . 4.3 L (4.7 qts)  
 Transmission Drive . . . . . Double V-Belt  
 Transmission Filter . . . . . Replaceable Internal Cartridge  
 Fan Blade Size . . . . . 9 in. Diameter  
 Axle Type/Wheel Hubs . . . . . Straight with Separate 5-Bolt Hubs  
 Cruise Control . . . . . Forward Travel, Lever on Dash  
 Travel Speeds at Full rpm  
 Forward . . . . . 0—11.2 km/h (0—7 mph)  
 Reverse . . . . . 0—6.4 km/h (0—4 mph)

**STEERING**

Type:  
 325 . . . . . Manual, Sealed Gearbox  
 335/345 . . . . . Power, Hydraulic, Front Wheels  
 Tilt Wheel (All tractors) . . . . . 5 Position

**BRAKES**

Location . . . . . Transmission  
 Type . . . . . Internal Wet Disk, Single Pedal  
 Parking Brake . . . . . Brake Pedal Lock Lever

**HYDRAULICS**

System . . . . . Lift (325)  
 . . . . . Lift and Steering (335/345)  
 Lift Control Valve  
 Type . . . . . Mechanical, Spool Valve  
 Location . . . . . Under Tunnel Cover  
 Cutting Unit Lift . . . . . Rear Cylinder  
 Filter . . . . . 10 Micron, Replaceable, In-Line

**IMPLEMENT LIFT**

Lift System	Hydraulic with Depth Stop
Lift Lever Location	Right-Hand Side of Dash
Cutting Heights (Independent of Lifts)	12.7—143.3 mm (6.35 mm increments)
	0.500—4.500 in. (0.250 in. increments)

Note: Heights may only be set while lift is in raised position.

**MOWER ATTACHMENTS**

Cutting Unit Drive	Belt
--------------------	------

**WEIGHTS AND DIMENSIONS**

Net Weight (less attachments and fuel)	
325/335	291.2 kg (642 lbs)
345	317.1 kg (699 lbs)
Mower Deck Weight	
38-Inch Mower Deck	.43 kg (95 lbs)
44-Inch Mower Deck	.49 kg (108 lbs)
48-Inch Mower Deck	.57 kg (125 lbs)
54-Inch Mower Deck	.64 kg (140 lbs)
Wheel Base	1.22 m (47.9 in.)
Tread Width	0.74 m (29 in.)
Turning Radius (inside rear wheel)	0.64 m (25 in.)
Overall Length (w/ 7 bushel rear bagger)	1.84 m (72.25 in.)
Overall Height	1.11 m (43.6 in.)
Overall Width (without attachments)	
With 38-Inch Mower Deck	1.33 m (52.60 in.)
With 44-Inch Mower Deck	1.16 m (45.70 in.)
With 48-Inch Mower Deck	1.52 m (60 in.)
With 54-Inch Mower Deck	1.68 m (66 in.)

**WHEELS AND TIRES**





















Front	16 x 6.50-8.00, 2PR, Turf
Inflation Pressure	69—97 kPa (10—15 psi)
Rear	23 x 10.50-12.00, Turf
Inflation Pressure	55—69 kPa (8—10 psi)

**Optional Tires:**

Front	16 x 6.50-8.00, 4PR, Turf
Inflation Pressure	69—97 kPa (10—15 psi)
Rear	23 x 10.50-12.00, Bar
Inflation Pressure	55—69 kPa (8—10 psi)

(Specifications and design subject to change without notice.)

**METRIC FASTENER TORQUE VALUES**

Property Class and Head Markings	4.8		8.8		9.8		10.9		12.9	
										
Property Class and Nut Markings	5		10		10		10		12	
										

TS1163

SIZE	Class 4.8				Class 8.8 or 9.8				Class 10.9				Class 12.9			
	Lubricated <sup>a</sup>		Dry <sup>a</sup>		Lubricated <sup>a</sup>		Dry <sup>a</sup>		Lubricated <sup>a</sup>		Dry <sup>a</sup>		Lubricated <sup>a</sup>		Dry <sup>a</sup>	
	N•m	lb-ft	N•m	lb-ft	N•m	lb-ft	N•m	lb-ft	N•m	lb-ft	N•m	lb-ft	N•m	lb-ft	N•m	lb-ft
M6	4.8	3.5	6	4.5	9	6.5	11	8.5	13	9.5	17	12	15	11.5	19	14.5
M8	12	8.5	15	11	22	16	28	20	32	24	40	30	37	28	47	35
M10	23	17	29	21	43	32	55	40	63	47	80	60	75	55	95	70
M12	40	29	50	37	75	55	95	70	110	80	140	105	130	95	165	120
M14	63	47	80	60	120	88	150	110	175	130	225	165	205	150	260	190
M16	100	73	125	92	190	140	240	175	275	200	350	225	320	240	400	300
M18	135	100	175	125	260	195	330	250	375	275	475	350	440	325	560	410
M20	190	140	240	180	375	275	475	350	530	400	675	500	625	460	800	580
M22	260	190	330	250	510	375	650	475	725	540	925	675	850	625	1075	800
M24	330	250	425	310	650	475	825	600	925	675	1150	850	1075	800	1350	1000
M27	490	360	625	450	950	700	1200	875	1350	1000	1700	1250	1600	1150	2000	1500
M30	675	490	850	625	1300	950	1650	1200	1850	1350	2300	1700	2150	1600	2700	2000
M33	900	675	1150	850	1750	1300	2200	1650	2500	1850	3150	2350	2900	2150	3700	2750
M36	1150	850	1450	1075	2250	1650	2850	2100	3200	2350	4050	3000	3750	2750	4750	3500

DO NOT use these hand torque values if a different torque value or tightening procedure is given for a specific application. Torque values listed are for general use only and include a ±10% variance factor. Check tightness of fasteners periodically. DO NOT use air powered wrenches.

Shear bolts are designed to fail under predetermined loads. Always replace shear bolts with identical grade.

Fasteners should be replaced with the same class. Make sure fastener threads are clean and that you properly start thread engagement. This will prevent them from failing when tightening.

When bolt and nut combination fasteners are used, torque values should be applied to the **NUT** instead of the bolt head.

Tighten toothed or serrated-type lock nuts to the full torque value.

<sup>a</sup> "Lubricated" means coated with a lubricant such as engine oil, or fasteners with phosphate and oil coatings. "Dry" means plain or zinc plated (yellow dichromate - Specification JDS117) without any lubrication.

Reference: JDS—G200.